

# XUM2APXBL2

Photoelectric sensors XU, miniature, thru beam, Smax=30 m, system, PNP, cable 2 m



## Main

Range of product	Telemecanique Photoelectric sensors XU
Series name	General purpose single mode
Electronic sensor type	Photo-electric sensor
Sensor name	XUM
Sensor design	Miniature
Detection system	Thru beam
Material	Plastic
Type of output signal	Discrete
Supply circuit type	DC
Wiring technique	3-wire
Discrete output type	PNP
Discrete output function	1 NO or 1 NC programmable
Electrical connection	Cable
Cable length	2 m
Emission	Red LED thru beam
[Sn] nominal sensing distance	20 m

## Complementary

Enclosure material	PBT
Lens material	PMMA
Maximum sensing distance	30 m
Output type	Solid state
Wire insulation material	PVC
Status LED	Supply on: 1 LED (green) Receiver/Output: 1 LED (orange) Receiver/supply on: 1 LED (green)
[Us] rated supply voltage	12...24 V DC with reverse polarity protection
Supply voltage limits	10...30 V DC
Switching capacity in mA	<= 100 mA with overload and short-circuit protection
Switching frequency	<= 1000 Hz
Maximum voltage drop	<2 V
Current consumption	20 mA for transmitter 20 mA for receiver
Maximum delay first up	100 ms
Maximum delay response	0.5 ms
Maximum delay recovery	0.5 ms
Setting-up	Sensitivity by potentiometer
Depth	20 mm
Height	33 mm
Width	10 mm
Net weight	0.119 kg
Kit composition	Transmitter + receiver XUM2AKXBL2T + XUM2APXBL2R

The information provided in this documentation contains general descriptions and/or technical characteristics of the performance of the products contained herein. This documentation is not intended as a substitute for and is not to be used for determining suitability or reliability of these products for specific user applications. It is the duty of any such user or integrator to perform the appropriate and complete risk analysis, evaluation and testing of the products with respect to the relevant specific application or use thereof. Neither TWSS Holding nor any of its affiliates or subsidiaries shall be responsible or liable for misuse of the information contained herein.

## Environment

Product certifications	CULus CE UKCA
Ambient air temperature for operation	-30...55 °C
Ambient air temperature for storage	-40...70 °C
Relative humidity	35...95 %
Immunity to ambient light	40000 Lux sunlight 10000 lux incandescent light
Vibration resistance	9 gn, amplitude = +/- 1.5 mm (f = 10...500 Hz) for every axis conforming to IEC 60068-2-6
Shock resistance	100 gn (duration = 11 ms) for every axis conforming to IEC 60068-2-27
IP degree of protection	IP67 conforming to IEC 60529 IP65 conforming to IEC 60529

## Packing Units

Unit Type of Package 1	PCE
Number of Units in Package 1	1
Package 1 Height	3 cm
Package 1 Width	12.5 cm
Package 1 Length	15 cm
Package 1 Weight	93 g
Unit Type of Package 2	S04
Number of Units in Package 2	80
Package 2 Height	30 cm
Package 2 Width	40 cm
Package 2 Length	60 cm
Package 2 Weight	9.2 kg

## Offer Sustainability

REACH Regulation	<a href="#">REACH Declaration</a>
EU RoHS Directive	Pro-active compliance (Product out of EU RoHS legal scope) <a href="#">EU RoHS Declaration</a>
Mercury free	Yes
China RoHS Regulation	<a href="#">China RoHS declaration</a>
RoHS exemption information	<a href="#">Yes</a>
California proposition 65	WARNING: This product can expose you to chemicals including: Diisononyl phthalate (DINP), which is known to the State of California to cause cancer, and Di-isodecyl phthalate (DIDP), which is known to the State of California to cause birth defects or other reproductive harm. For more information go to <a href="http://www.P65Warnings.ca.gov">www.P65Warnings.ca.gov</a>

## Contractual warranty

Warranty	18 months
----------	-----------

Dimensions

Transmitter

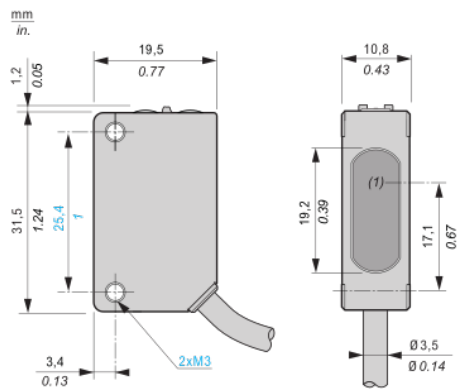

(1) : Transmission

Receiver

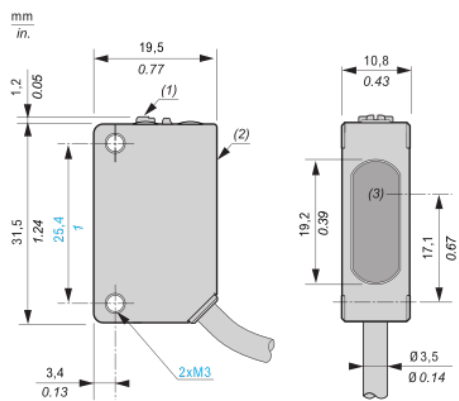

- (1) : Setting potentiometer (sensitivity)
- (2) : Setting potentiometer (output)
- (3) : Reception

---

## Connection and schema

---

### Wiring diagram

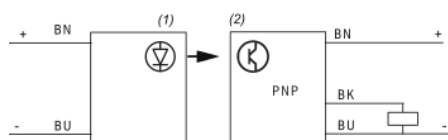

BN (Brown): (+)

BK (Black): OUT/Output

BU (Blue): (-)

(1): Transmitter

(2): Receiver

Detection curves

Lateral displacement

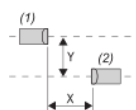
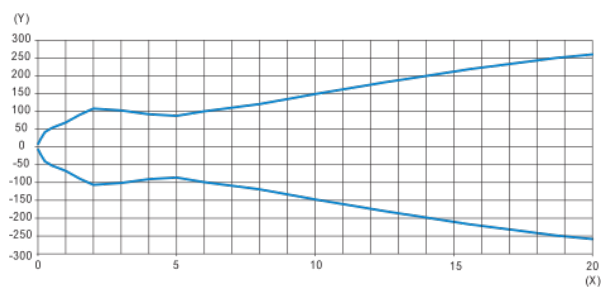

- (1): Transmitter
- (2): Receiver
- (X): Sensing distance (m)
- (Y): Lateral displacement (mm)

Light beam diameter

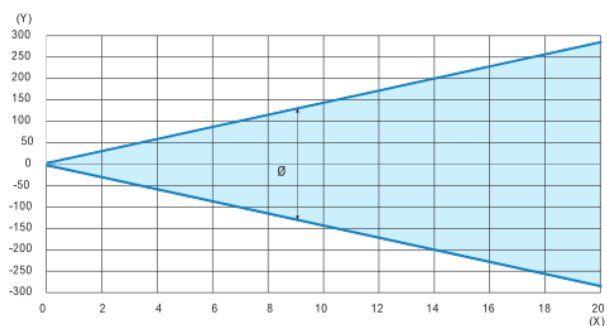

- (X): Sensing distance (m)
- (Y): Light beam diameter (mm)

Excess gain

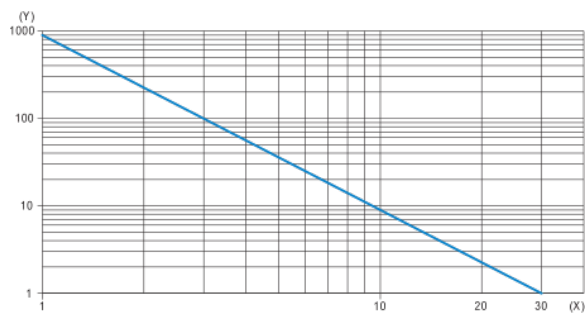

- (X): Sensing distance (m)
- (Y): Excess gain